

Introduction

No non-invasive technique can precisely establish the true chemical composition of the contents of a sealed container.

In order to provide sufficient information for appropriate action to be taken a physical sample is required. Although the mmic **'monica'** case entry/sampling system has many advantages, there are situations where the ability rapidly to take a small sample of the contents of a container is essential.

To this end mmic has produced the **'midas'** single-use sampler, allowing access to the contents of a container in a simple, safe, reliable and completely leak-free approach.

Applications for the equipment include the sampling of suspected CW (Chemical Warfare) materials and TIC's (Toxic Industrial Chemicals).

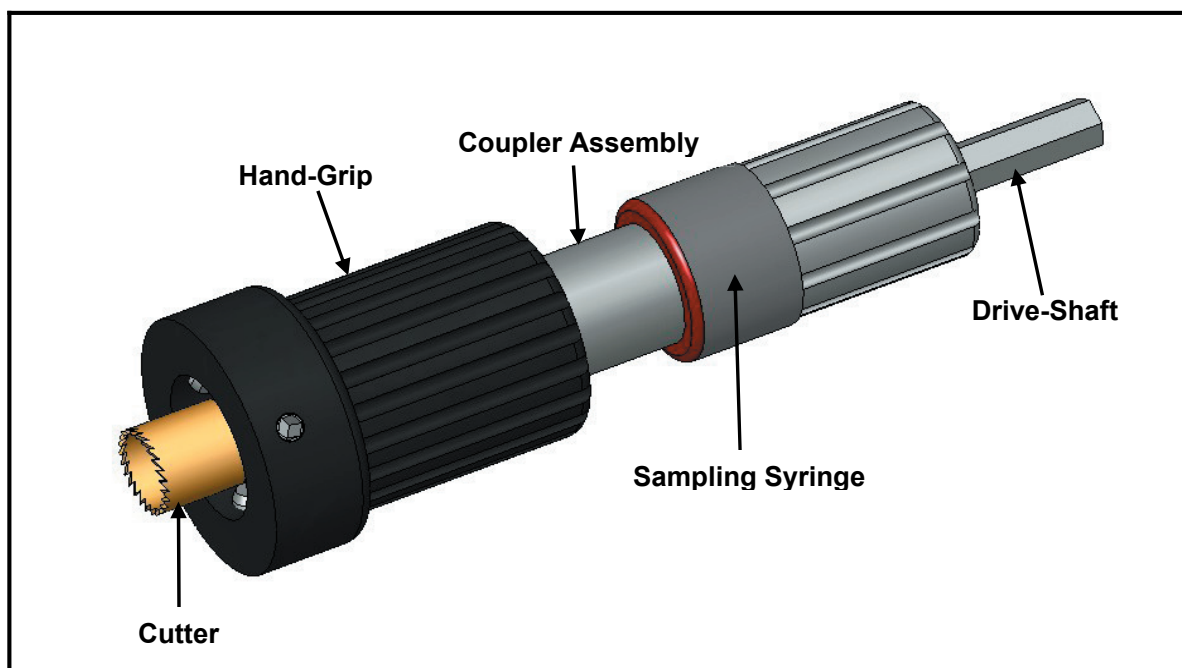

Function and Capabilities

The equipment consists of a probe assembly comprised of a 10 mm diameter cutter (capable of drilling up to 10 mm thickness of metal, plastic or wood), a seal which prevents leakage once the target is breached and an integral quick-release sampling syringe assembly.

The drive-shaft is fitted into the chuck of a cordless electric drill, or other drilling machine.

The sealing mechanism deals effectively with targets of a range of diameters and wall materials- a prototype has successfully drilled and sealed a plastic 'soft drinks' bottle containing fluid.

The equipment is ideally suited to obtaining a diagnostic sample for on or off-site analysis from almost any container.

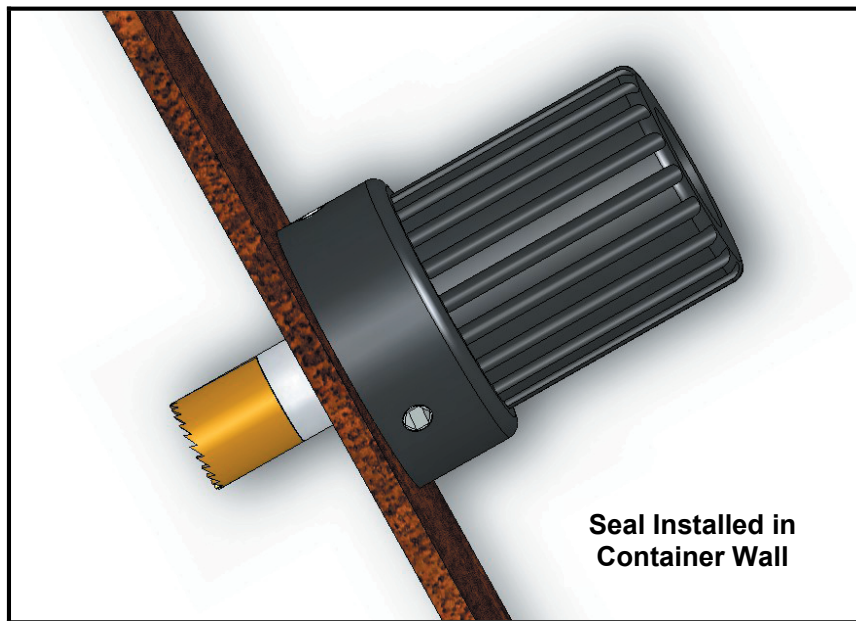

In the above picture the equipment has fully installed, the chemically-resistant seal has been drawn up onto the inside wall of the target, forming a gas-tight seal.

The probe assembly will seal on wall thicknesses between 1 and 10 mm, and with internal pressures up to 4 Bar (~60 PSI).

The operator has only to drill into the target, the seal installing automatically.

Pulling the drilling machine back takes a 4 ml (max) sample and then unlocks the syringe from the probe sealing both the probe, which remains in the target to allow further procedures including repeat sampling, and the syringe which stays in the drill chuck.

The operator does not come into contact with the sample or the sampling syringe at any time.

The entire syringe assembly thus contains a sealed sample of the container's contents which is designed to be packed in a standard IATA approved container for transport to an analytical laboratory.

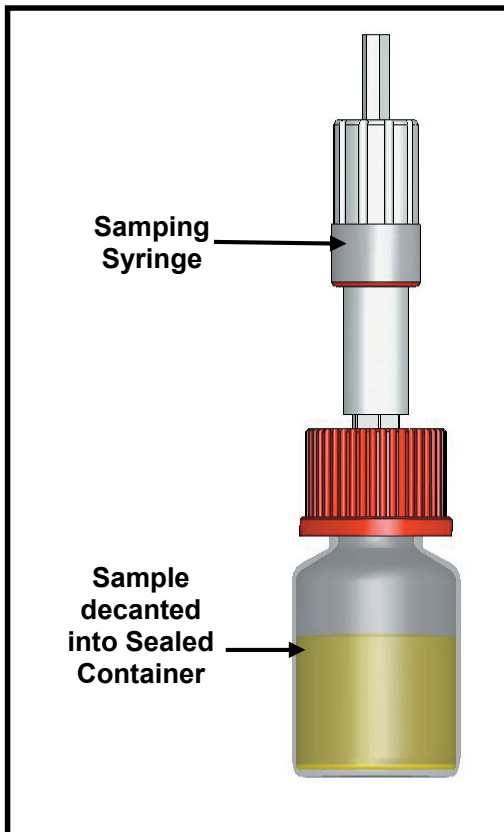

Alternatively, a sealed sample downloader can be provided which aliquots the sample depending on the analytical equipment requirements, most equipment generally requiring a sample of only a few micro-liters for 'on-the-spot' analysis.

All materials used in the '**midas**' system are designed to be resistant to a wide range of CW agents and TIC's and are compatible with applicable Def-Stan's.

The equipment is produced under 'clean-room' conditions and vacuum-packed in order to prevent cross-contamination.

An optional diamond core cutter allows glass and ceramic targets to be drilled and sampled.

The all-up weight of the system is under 100 grammes, with a total size of approximately 150 x 40mm when packed in its transport container.

The system is supplied in a ruggedized 'Peli-Case'. A range of probe types, other manual sampling equipment and a suitable high-quality cordless drill may be provided if required.